

DADI ESAGONALI AUTOBLOCCANTI ALTI INSERTO IN NYLON NYLON INSERT HIGH HEX LOCK NUTS

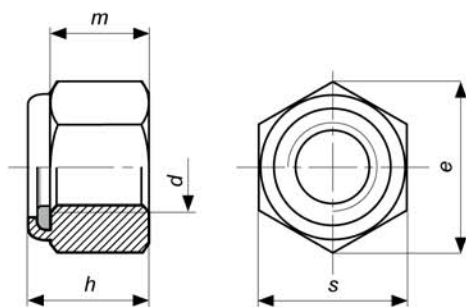

FILETTATURA METRICA ISO A PASSO GROSSO E FINE / ISO METRIC COARSE AND FINE PITCH



DISPONIBILI: Zincato bianco o Zincato giallo secondo RoHS
Altri trattamenti a richiesta

AVAILABLE: White zinc plated or Yellow zinc plated according to RoHS
Other coatings on request

ISO	UNI	DIN
7040-10512*	7473	982
MATERIALE	ACCIAIO	
MATERIAL	STEEL	
PROPRIETÀ MECCANICHE	SECONDO	DIN 267 UNI 3740-4 ISO 2320
MECHANICAL PROPERTIES	ACCORDING TO	
CLASSE		
CLASS		
TOLLERANZE	SECONDO	ISO 4759-1 CAT A
TOLLERANCES	ACCORDING TO	

d	s	e min	h	m	passo grosso coarse thread		passo fino fine thread	
M 3	5,5		4		0,5			
M 4	7	7,74	5,8	3,2	0,7	1,1		
M 5	8	8,87	6,3	3,5	0,8	1,6		
M 6	10	11,05	8	4,5	1	2,9		
M 7	11	12,12	8,8	5,6	1	3,8		
M 8	13	14,38	9,5	6,5	1,25	6,3	1	6,23
M 10	17	18,90	11,5	8	1,5	13,6	1	13,6
M 10	17	18,90	11,5	8	1,5	13,6	1,25	13,6
M 12	19	21,10	14	10	1,75	19,3	1,25	18,9
M 12	19	21,10	14	10	1,75	19,3	1,5	18,9
M 14	22	24,49	16	11	2	29,2	1,5	28,6
M 16	24	26,75	18	12,8	2	37,7	1,5	37
M 18	27	30,14	20	14,4	2,5	54,0	1,5	52,4
M 20	30	33,53	22	16	2,5	73	1,5	70,4
M 22	32	35,72	25	17,6	2,5	88	1,5	84,5
M 24	36	39,98	28	19	3	125	2	122
M 27	41	45,63	31	21,6	3	183	2	179
M 30	46	51,28	33	24	3,5	258	2	250
M 33	50	55,80	35	24	3,5	326	2	318
M 36	55	61,31	39	28	4	424	3	418
M 39	60	66,96	42	31	4	561	3	552
M 42	65	72,61	45	33	4,5	662	3	628
M 45	70	78,26	47	36	4,5	860	3	
M 48	75	93,56	50	38	5	980	3	

 PESO PER 1000 PEZZI / WEIGHT FOR 1000 PCS

(*) La norma ISO 7040 si riferisce al passo grosso la ISO 10512 si riferisce al passo fine.

(*) ISO 7040 norm includes coarse thread nuts, ISO 10512 fine thread nuts.